

RoboElectronics X2 : Mains Power

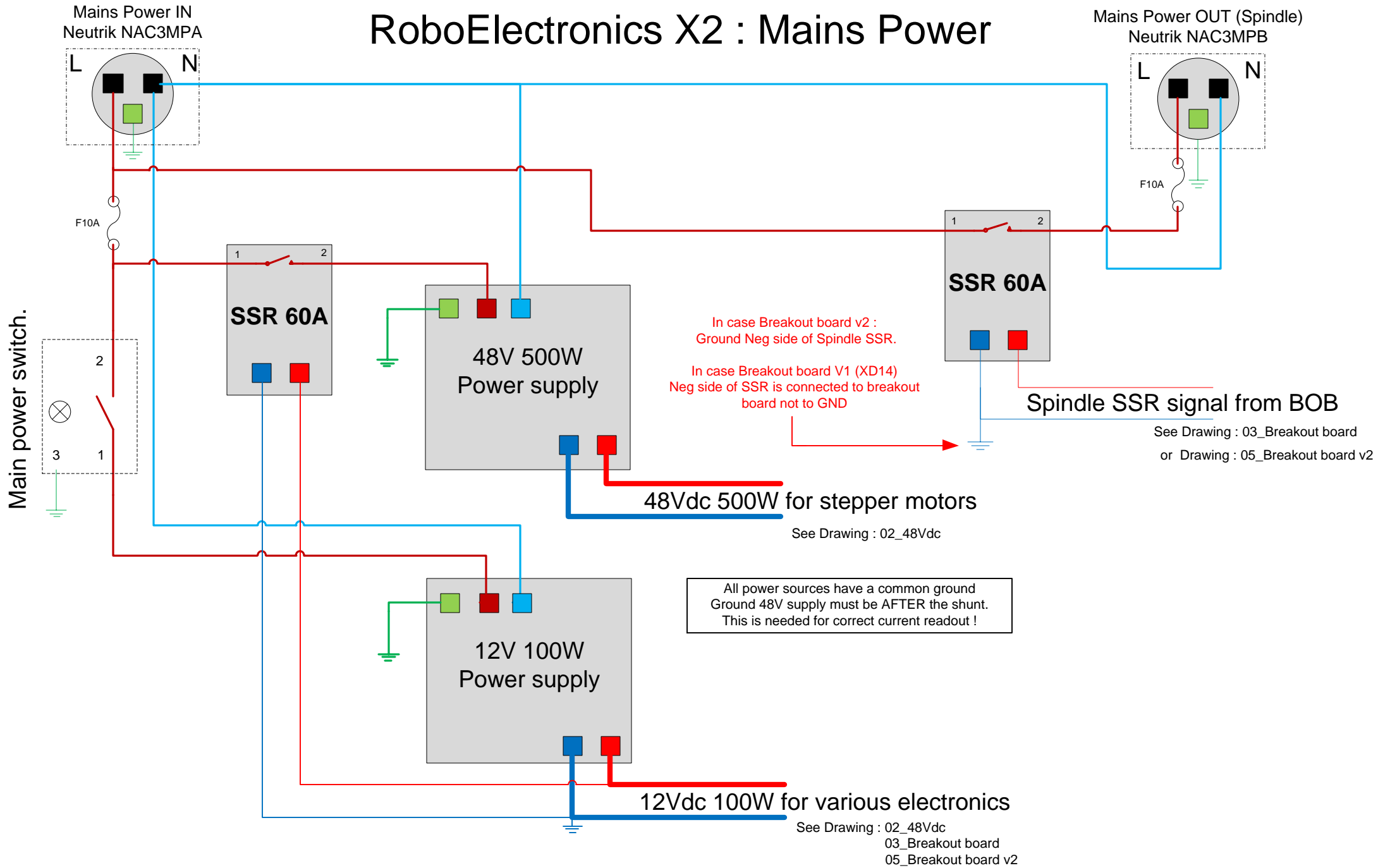

RoboElectronics X2 : 48Vdc

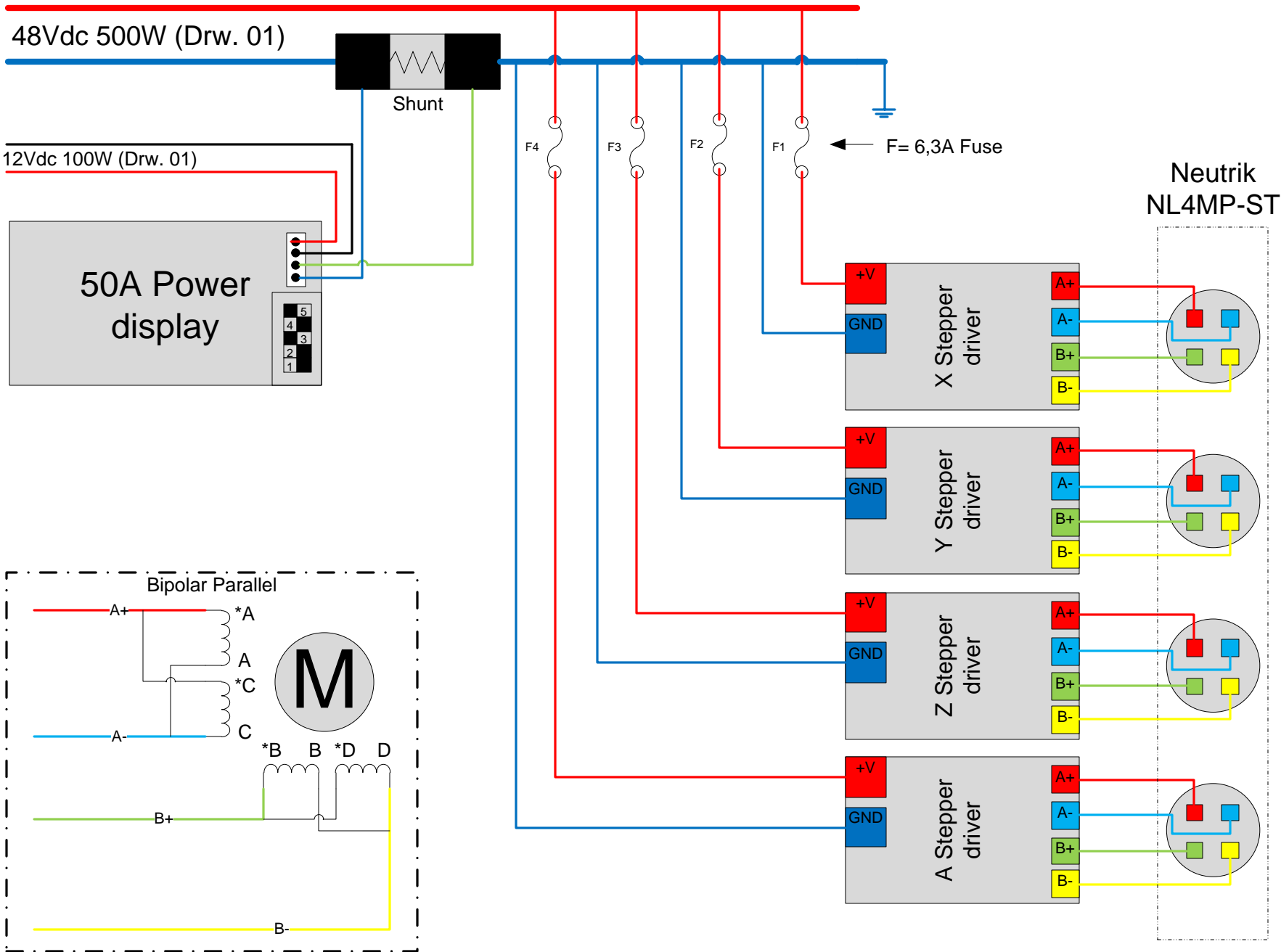

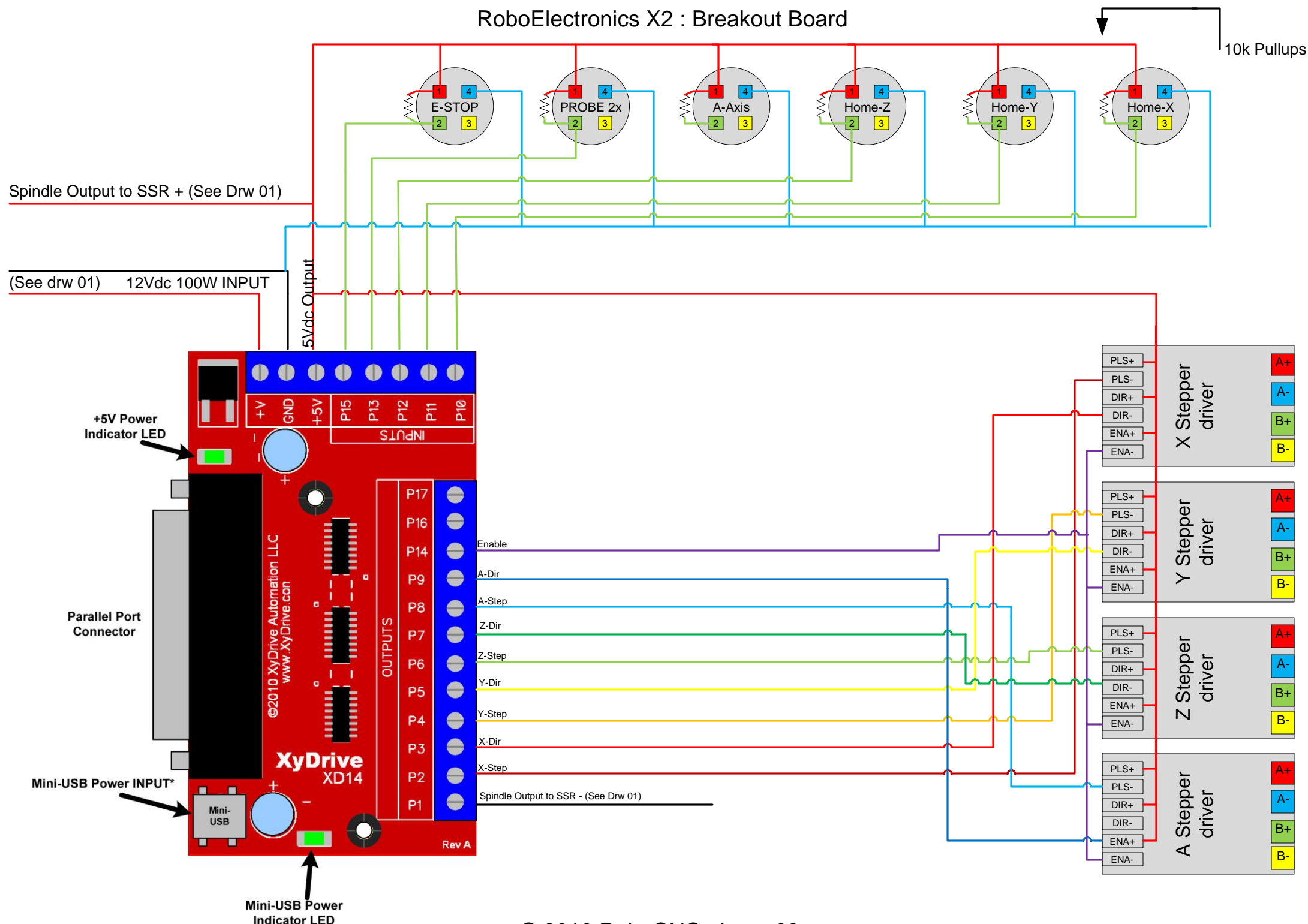

RoboElectronics X2 : PoKeys55T (to be continued)

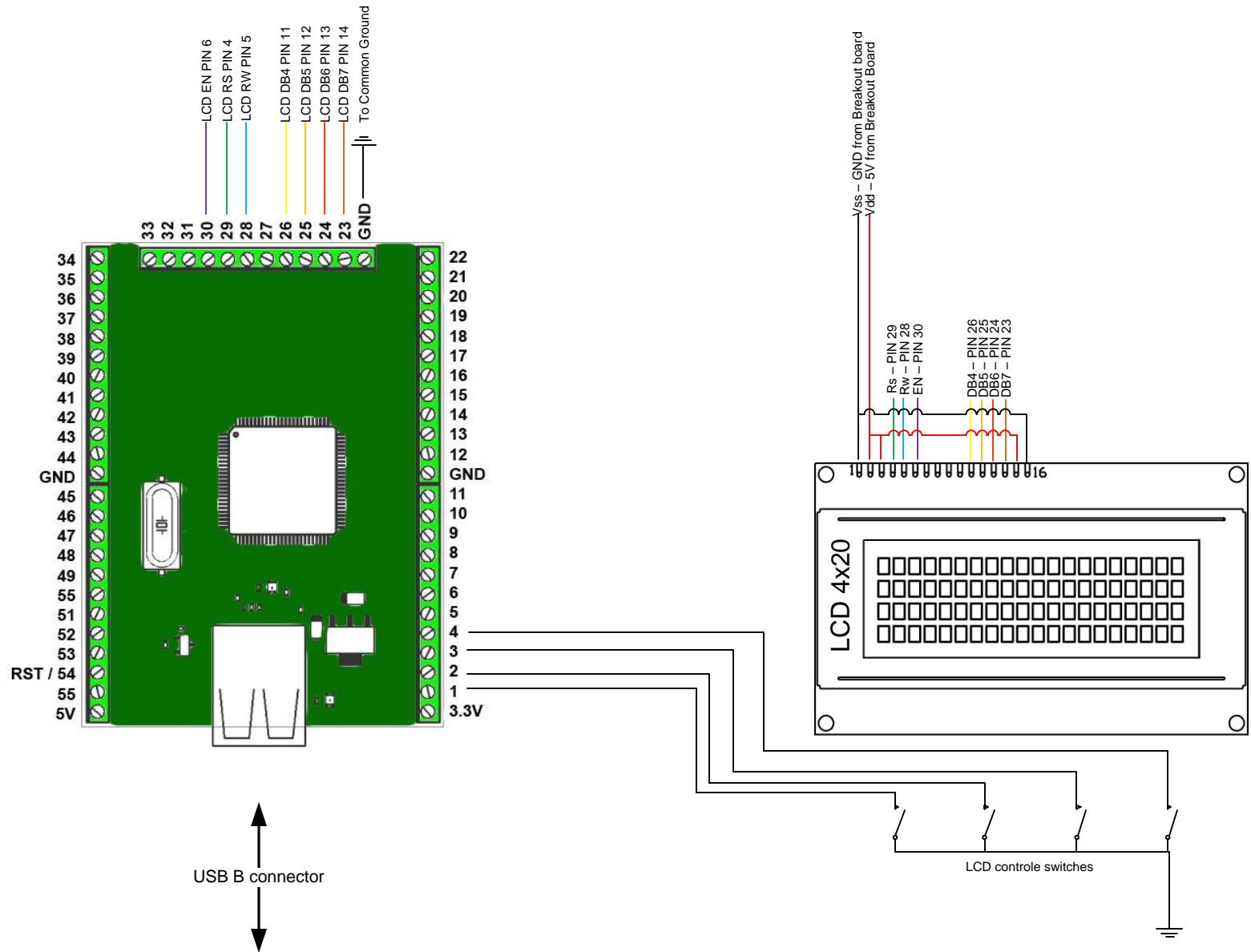

RoboElectronics X2 : Breakout Board v2

